

V3211

2-Wide QMC Versal® AI Edge / Prime Gen 2 Adaptive SoC SOM

Benefits

Embedded Small Form Factor (SFF) VITA 93 Double-Width QMC mezzanine, suited for harsh conditions and rugged applications.

Programmable interface solution that leverages off-the-shelf world-class network interfaces and adaptive System-on-Chip (SoC) functionality.

Heterogeneous computing card combining hard ARM processor cores, AI engine cores, large FPGA fabric, and high-bandwidth network interface controllers.

Specifically designed for sensor interface, digital signal processing, video processing, secure networking, and AI workload acceleration.

Deployable into VNX+, 3U/4U/6U VPX, PCIe, CompactPCI and many other carrier-card systems.

VITA 93 and VITA 47 compliance.

Features

- Rugged iTemp double-width QMC SFF mezzanine
- AMD Versal® Gen 2: 2VM3858 (Prime), 2VE3858 (AI Edge)
- 2 banks of 32GB (64GB total) up to 3200MHz / 6400 Mbps LPDDR5 SDRAM.
- Four (4) PS electrical high-speed lanes with dedicated CPM5 PCIe Gen5x4 controller.
- Sixteen (16) PL GTYP electrical high-speed lanes suitable for 1G to 32G networking and PCIe Gen4/Gen5 interfaces.
- Up to 24 LVCMOS 3.3V PS+PL GPIO
- PL hard silicon in Versal® Adaptive SoC device:
4 x PLPCIE5 3 x MRMAC 3 x ISP
- Thermal sensors for monitoring card temperature
- Robust FPGA example design with BSP

Overview

The V3211 is a next generation heterogeneous embedded computing double-width QMC SOM featuring the AMD Versal® AI Edge or Prime Gen 2 Adaptive System-on-Chip (SoC). The V3211 allows footprint compatible part selection of Versal® 2VM3858 or 2VE3858 devices. In a double-width QMC, the V3211 provides up to 4 x 32G and 2 x 25G high-speed PS serdes, 16 x 32G high-speed PL serdes, 1GbE SGMII electrical lane, up to 24 x LVCMOS 3.3V PS+PL GPIO, and PL support for 543K LUTs and 2064 DSP engines.

The V3211 QMC SOM excels at high-bandwidth interface applications where data is processed or pre-processed locally and then distributed to carrier-card and backplane interfaces. Use cases include drones, munitions, air launched effects, packable electronics warfare, ground vehicle computers, sensor interface, data processing, data distribution, FPGA and AI engine co-processing applications. Radar, signals intelligence, electronic warfare, video, storage, medical imaging, and embedded communications systems all can benefit from the V3211.

By leveraging the Versal® hard silicon Ethernet interfaces, PCIe controllers, DMA engines, and associated software drivers AMD has enabled a robust ecosystem for high-bandwidth Ethernet performance. In addition to the Ethernet interface, the FPGA fabric provided within the adaptive SoC part is capable of hosting New Wave Design IP cores for Fibre Channel, ARINC-818, sFPDP, Aurora, and others. This makes the V3211 an ideal hardware platform for mixed interface protocol needs or protocol bridging applications.

The V3211 serves as a highly-integrated data interface and processing solution in a compact double-width QMC. The V3211 is deployable into VNX+, 3U/4U/6U VPX, PCI, CompactPCI and most any other carrier card system. In this arrangement, carrier-card CPU's/GPUs are unburdened of the data interface overhead and can be dedicated to running high value applications and algorithms with the V3211 performing dedicated compute acceleration functions.

The convenient QMC SOM form factor and rugged design of the V3211 can, for example, turn a VNX+ based single board computer into a single-slot heterogeneous computing solution.

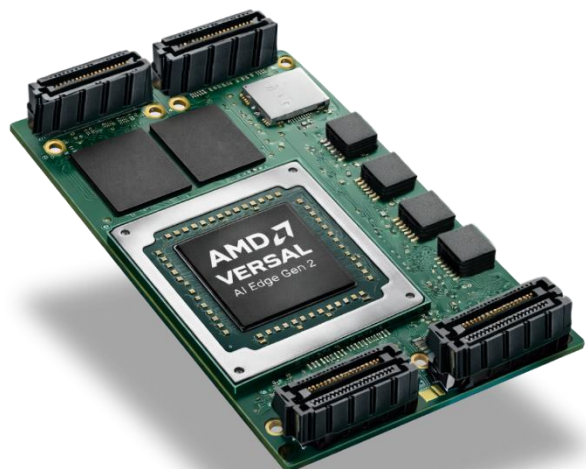

V3211

2-Wide QMC Versal® AI Edge / Prime Gen 2 Adaptive SoC SOM

V3211 block diagram as depicted from primary (connector) side.

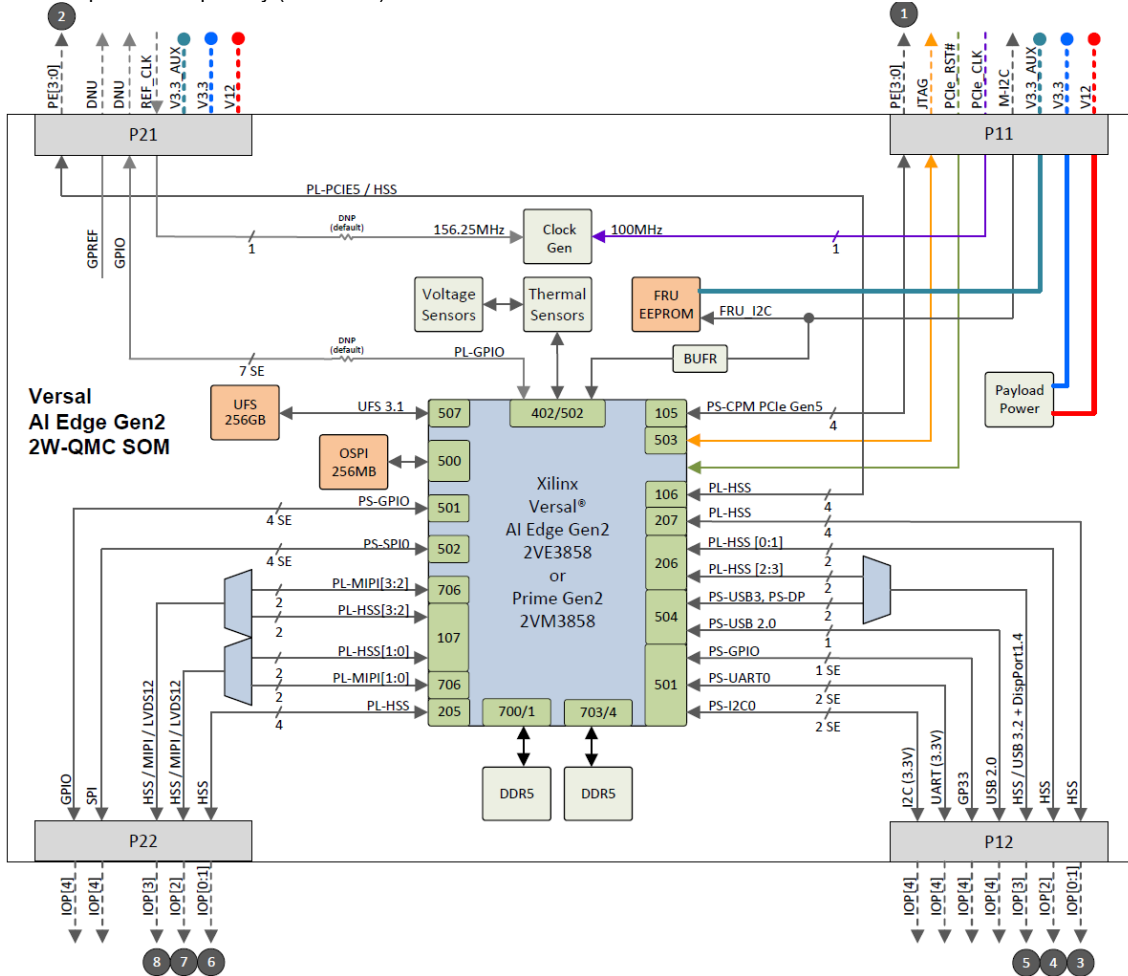

Board Placement

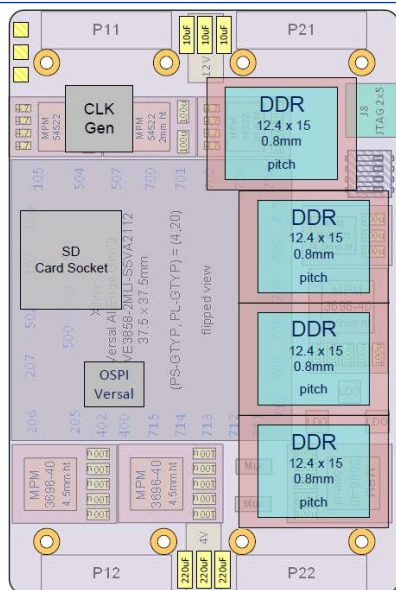

Board placement as depicted from secondary side, representative of when board is placed on carrier card.

Drawing to scale when printed on 8.5 x 11" paper using "Actual Size".

Multi-Processor Multi-Core Support

The V3211 is uniquely suited for system architectures involving multiple processing cards on a common switched data plane. Specifically, the V3211 supports shared access from multiple host processors, enabling it to function as a cost-effective, high-performance gateway. This feature enables a single high-speed pipe to carry multiple virtual channels in systems that need to spread or load-balance sensor data across processor arrays.

Complete Product Support Program

New Wave prides itself on its excellent customer support, a fact that is echoed by our customers. New Wave Design provides industry standard warranty on its products, but it is the human factor that makes our support so valuable to our customers. Our team takes the time and effort to ensure that the customer experience with our products is a positive one.

Our Commitment

New Wave is committed to providing the latest innovations in technology, architectures, and techniques to keep our customers one step ahead of the rest. Our products, complete with the Development Framework, are intended to offer our customers an entirely unique out-of-the-box experience.

Development Environment

The V3211 comes standalone or optionally with a Baseboard Transition Module (BTM) offering a complete system development environment. The BTM can support up to 2 accessory QMC modules. Examples include Samtec Optical Firefly QMC and M.2 QMC modules. All V3211 high-speed and GPIO interfaces are made accessible via the BTM. The BTM also provides access to all JTAG, GbE, HSDP, and serial port connections for development and debug.

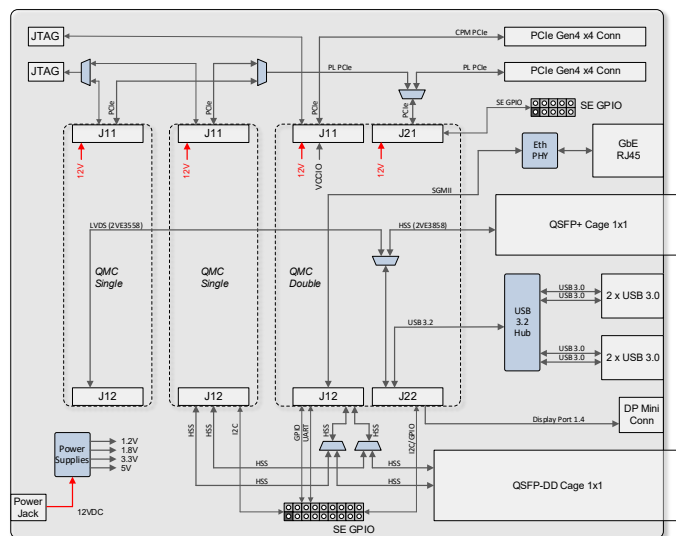

Technical Specifications

HOST PCIe INTERFACE

One Versal PS CPM5 hard block provisionable into a Gen5x4 PCIe connection.

Up to 4 PL PCIe5 hard blocks provisionable into 3 x Gen4x4 + 1 x Gen4x2 PCIe connections.

NETWORK INTERFACE

Up to seventeen (17) 1G to 25G electrical high-speed lanes suitable for Ethernet networking connections.

ETHERNET PROTOCOLS

TCP, UDP, ARP, ICMP

ADDITIONAL PROTOCOLS

Fibre Channel, sFPDP, ARINC 818, Aurora

ADAPTIVE SoC DEVICE

AMD Versal® AI Edge Series Gen 2 2VE3858 /

AMD Versal® Prime Series Gen 2 2VM3858

Visit AMD Versal® Datasheet¹

Contact New Wave Design for additional device support!

MEMORY

2 banks of 32GB (64GB total) up to 3200MHz / 6400 Mbps LPDDR5 SDRAM

THERMAL & VOLTAGE SENSORS

2 digital temperature sensors and multiple voltage sensors.

COMPLIANCE

VITA 47, 74, 90, 93

PHYSICAL CHARACTERISTICS

Dimensions:

78.0 mm (length) x 51.875 mm (width) x 7.4mm (thickness)

4.5mm Primary side max component height

1.6mm PCB thickness

1.3mm Secondary side max component height

Weight:

<0.25 lbs (115 g)

POWER CHARACTERISTICS

Power Draw (Max): 35W

Power Supply: 12V, 3.3V_AUX

TEMPERATURE

Operating: -40° C to 85° C (conduction-cooled)

Storage: -55° C to 105° C

¹AMD Versal® AI Edge Gen 2 adaptive SoC Datasheet:

<https://www.amd.com/en/products/adaptive-socs-and-fpgas/versal/gen2/ai-edge-series.html>

This datasheet is preliminary information and subject to change.

V3211 Hardware Part Number Configuration

400 - **03211**
Series Model

“WXYZ”
Board Configuration

Select 1 for each W, X, Y, and Z

“IP”
IP Configuration

Select 1 IP Option

Optional
“CC”
Coating Configuration

Select 1 Coating Option

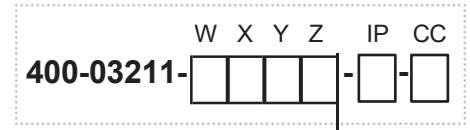

W

Config # Description

4+	Reserved
3	AMD Versal 2VE3858 AI Edge Gen 2
2	Reserved
1	AMD Versal 2VM3858 Prime Gen 2
0	Reserved

X

Config # Description

0	Reserved
---	----------

Y

Config # Description

0	Conduction cooled, 19mm pitch
---	-------------------------------

Z

Config # Description

3+	Reserved
2	Industrial Temp
1	Reserved
0	Reserved

IP

Config # Description

1+	Reserved
00	Example design package

CC

Config # Description

AR	Acrylic conformal coat
UR	Urethane conformal coat
ER	Epoxy conformal coat
SR	Silicone conformal coat
XY	Parylene conformal coat
BLANK	No conformal coat

V3211 “Go-Fast” Hardware Part Numbers

Part Numbers available with the shortest lead times.

Config #	Description
400-03211-1002-00	V3211 FPGA Double-Width QMC Card, AMD Versal 2VM3858 Prime Gen 2 Adaptive SoC, PCIe Gen5 x 4, 16 x HSS 1-32Gbps, 1 x GbE SGMII, conduction cooled, 19mm pitch, industrial temp, example design package
400-03211-3002-00	V3211 FPGA Double-Width QMC Card, AMD Versal 2VE3858 AI Edge Gen 2 Adaptive SoC, PCIe Gen5 x 4, 16 x HSS 1-32Gbps, 1 x GbE SGMII, conduction cooled, 19mm pitch, industrial temp, example design package

FOR MORE INFORMATION

www.newwavedesign.com
info@newwavedesign.com
Phone +1 952-224-9201

New Wave Design
10260 Viking Drive, Ste 250
Eden Prairie, MN 55344 USA

 **New Wave Design**